



## **LIDLAW UNDERGRADUATE RESEARCH AND LEADERSHIP SCHOLARSHIP PROGRAM**

### **FINAL REPORT**

**PROJECT-NAME: DESIGNING/ PROTOTYPING CELLPHONE  
DETECTING SYSTEM FOR HIGHSCHOOL AND PRIMARY  
STUDENTS' SURVEILLANCE**

**(A solution to education developed with available and cheap components.)**

**SCHOLAR: INKINDI MUTONI SABINE**

**REGISTRATION NUMBER: 218000712**

**UNIVERSITY OF RWANDA**

**COLLEGE OF SCIENCE AND TECHNOLOGY**

**SCHOOL OF ENGINEERING**

**DEPARTMENT OF ELECTRICAL AND ELECTRONICS  
ENGINEERING**

**YEAR OF STUDY: YEAR 3**

**PHONE NUMBER: 0789799980**

**MENTOR: LECTURER HITIYISE EMMANUEL**

**TITLE: LECTURER**

**EMAIL: hitiemmy@yahoo.com**

**DATE: 13<sup>th</sup> April 2021**

## **DECLARATION**

I hereby declare that the project report entitled “Designing/ prototyping cellphone detecting system for high school and primary students’ surveillance” submitted by me (Inkindi Mutoni Sabine) under the Laidlaw Undergraduate Research and Leadership Scholarship Program to the University of Rwanda/ College of Science and Technology is a record of the work done by me during the program under the supervision of Lecturer Hitiyise Emmanuel. All details and analysis provided in this report are true to the best of my knowledge.

I further declare that the work reported in this project has not been submitted and will not be submitted to any institute or university.

Date: 13<sup>th</sup>/ 4/ 2021

## APPROVAL

This project report has been submitted to Laidlaw scholarship program with the approval of the following supervisor:

Supervisor Name: Lecturer Hitiyise Emmanuel

School of Engineering

Department of Electrical and Electronics Engineering

Signature:

A handwritten signature in blue ink, appearing to be 'Hitiyise Emmanuel', written on a light blue background.

Date: 13<sup>th</sup>/4/2021

## **ACKNOWLEDGEMENT**

I would like to express my sincere appreciation to the Laidlaw foundation for this scholarship which enabled me to work on my chosen project while gaining research and leadership skills. Throughout the program, I have been able to expand my knowledge in Engineering subjects while working on the project. I have also been able to develop research skills which was the key to move from one step to another.

I want to thank a lot Lecturer Hitiyise Emmanuel for his direction during this project. When I started to work on this project, Lecturer Hitiyise advised me on the concepts I should read in order to proceed with the work. During the first weeks of the project, I ran to him very often for guidance and he was always available to answer my questions despite his highly demanding schedule. I gained from him more knowledge in Electronics which helped me to continue working on the project while understanding what I was doing. I would highly recommend him to my colleagues in the future.

## LIST OF ABBREVIATIONS

<b>Abbreviations</b>	<b>Definition</b>
1G	First generation
2G	Second generation
3G	Third generation
4G	Fourth generation
CMRR	Common Mode Rejection Ratio
HSPA	High Speed Packet Access
ICT	Information and Communications Technology
LED	Light Emitting Diode
MOSFET	Metal Oxide Semiconductor Field Effect Transistor
<i>USB</i>	Universal Serial Bus

## ABSTRACT

With certain features being added to cell phones, there is no doubt that it is playing a significant role in society today. A cell phone makes communication easy and fast. It helps in transferring and sharing data without leaving where you are. Even though the cellphones are very helpful and important, if they are used in a non-ethical manner, they can bring negative consequences. If students in the class are using cellphones instead of studying while keeping exchanging information with strangers, they may lose their attention to their lessons and later forget that their core duty of studying. The same happens when workers at the hospital are using their cellphones instead of taking care of the patients. This research aims at building a cellphone detecting system that will help in making sure that cellphones are not being used in places where they are prohibited. It is divided into two parts which are the following:

- The simulation part and
- The implementation part

The simulation is done in order to test how the components work before they are being put on the breadboard so as to avoid the wastage of unnecessary hardware. The implementation part deals with making the final part of the circuit. Even though this circuit has a record of being developed in the past, there is no clear evidence that shows it is being used in Rwanda and yet it can play a wonderful advantage in education. Being able to develop it using cheap materials can also make it easier to be used in all places where it is needed.

*Keywords:*

- Cellphone detector, multisim, LTspice

# TABLE OF CONTENTS

<b>CHAPTER 1 GENERAL INTRODUCTION</b>	1
<b>1.1 INTRODUCTION</b>	1
1.1.1 Cell phone today	1
1.1.2 Cell phone technology	1
<b>1.2 PROBLEM STATEMENT</b>	2
<b>1.3 OBJECTIVES</b>	3
1.4.1 Main objectives	3
1.4.2 Specific objectives	3
<b>1.4 SCOPE</b>	3
<b>1.5 SIGNIFICANCE</b>	3
<b>CHAPTER 2 LITERATURE REVIEW</b>	4
<b>CHAPTER 3 SYSTEM ANALYSIS AND DESIGN</b>	5
<b>CHAPTER 4 SYSTEM DEVELOPMENT, IMPLEMENTATION AND RESULTS</b>	8
<b>4.1 Development</b>	8
<b>4.2 Implementation</b>	10
<b>4.3 Results</b>	16
<b>CHAPTER 5 CONCLUSION AND RECOMMENDATION</b>	18
<b>5.1 RECOMMENDATION</b>	18
<b>5.2 CONCLUSION</b>	18
<b>REFERENCES</b>	19

## LIST OF FIGURES

Figure 1 - Multisim project window .....	6
Figure 2 - LTspice project window .....	7
Figure 3 - the first part of the circuit (detection part) .....	10
Figure 4 - the detection part of the 2G and 3G circuit. ....	11
Figure 5 - the whole circuit including the part of sound generation and the simulation.....	12
Figure 6 - The detection part of the circuit and the sound generation part alone. ....	13
Figure 7 - circuit implemented on the breadboard for 2G and 3G networks .....	14
Figure 8 - The simulated circuit for 2G networks in the multisim .....	14
Figure 9 - the 2G circuit simulated in the multisim for the input signal at low frequencies. ..	15
Figure 10 - The 2G network circuit soldered on the PCB.....	15
Figure 11 - LED blinking while making a phone call.....	16
Figure 12 - The circuit simulated inside the box .....	17
Figure 13 - Cell phone detector enclosed (device) with cell phone aside .....	17
Figure 14 - circuit being worked on for 3G networks.....	18
Figure 15 - circuit for 3G, 4G networks after soldering on PCB .....	19

# CHAPTER 1 GENERAL INTRODUCTION

## 1.1 INTRODUCTION

### 1.1.1 Cell phone today

Cell Phones have become part of our everyday life. In every minute we are using them to connect to our loved ones and to the world. They have made communication easier and in every single moment, there is a need for them. Mobile technology has spread rapidly around the globe. Today, it is estimated that more than 5 billion people have mobile devices, and over half of these connections are smartphones [1]. The world today is inconceivable without cell phones because they have affected almost every field of life. This small device has done that work that was not even accomplished by great leaders and even wonderful inventions. It has made the people closer and closer day by day [2]. Studies have shown that mobile phones are used in different settings including restaurants, grocery stores, buses, trains, and movie theaters [3]. According to Ling, the mobile phone has fundamentally affected our accessibility, safety and security, coordination of social and business activities, and use of public places [4]. In their study, Wei and Leung found classrooms to be among the least acceptable places for cellphones [5]. Participants reported that they could tolerate cell phone use on streets, at meetings, at friends' houses, at shopping malls, and in public transportations.

Campbell also found similar results in a study where he was assessing the perceptions of mobile phone use in various public settings. Participants in his study reported talking on cell phones while on public sidewalks, in grocery stores, and on buses to be socially acceptable while they strongly regarded the use of technology in classrooms and movie theatre as unacceptable. The aim of this research project was to test and prototype the cellphone detecting system while the key point is to reduce the number of students who enter the schools with cell phones [6].

### 1.1.2 Cell phone technology

Cell Phones have got many features which will be increasing in years to come. Among those features, we have:

- *Bluetooth*: a wireless technology that uses a radio frequency to share data over a short distance, eliminating the need for wires. You can use Bluetooth on your mobile device to share documents or to connect with other Bluetooth-enabled devices. It is a secure wireless protocol that operates at 2.4 GHz. Devices like a printer, keyboard, mouse, audio device, and storage device can be connected wirelessly. This feature is

mainly used for hands-free devices but can also be used for file transfer of pictures, music, and other data.

- *USB*: a way for cellular phones to connect to a computer for data transfer. This feature is very similar to Bluetooth for a cellular phone with the exception of using a cable. This feature is mainly used for charging the battery or programming by the manufacturer. It can also be used to transfer pictures, music, and other data.

- *Cameras*: a very popular feature on the cellphone. Most cellular phones will come with at least a 2-megapixel camera and the more expensive phones can be as many as 8 megapixels.

- *Microphones*

Almost all cell phones are currently connected to the internet which allows people to share files and data wherever they are. Cell Phones can send emails, text messages, picture text messages, video text messages, and upload data to the Internet.

With all features above, there include the memory cards which are used to increase the memory of the cell phones. There is no doubt that in the coming years, manufacturers will keep adding many more features [7].

## **1.2 PROBLEM STATEMENT**

Even though there is a need for improvement in the use of ICT devices in primary and secondary schools, the government of Rwanda has put emphasis on banning cell phones. This is because some kind of cellphone usage is bringing challenges to education in Rwanda. Banning cell phones is in accordance with the Ministerial Instructions N°001/MINEDUC/2018 of 11/07/2018 prohibiting students from using mobile telephones [8]. This is because there are many bad consequences and cases of indiscipline that were shown to result from them, including attraction to drugs as they see this on social media, unplanned pregnancies for girls as they interact with the outside world while at school, and many other distractions. Furthermore, a study conducted by the ministry of education revealed that when students use phones at school, it affects their studies as they spend most of their time on them and forget about their core duty of studying [9]. This research aims at analyzing the successfulness of a

cell phone detector which will be used in order to know if cellphones are present in a place where they are prohibited. This will discourage many students from disturbing others because the time they will be taken; severe punishments will be taken aiming to reduce carelessness among students resulting from the use of cell phones.

### **1.3 OBJECTIVES**

#### **1.3.1 Main objectives**

The prime objective of the research project is to analyze and implement the cell phone detecting system.

#### **1.3.2 Specific objectives**

Doing the simulation and implementation for 2G, 3G, and 4G networks.

### **1.4 SCOPE**

This project involves 2 steps: the simulation part and the implementation part. The simulation part involves using two electronics simulators which are LTspice and Multisim. The circuit will be drawn and simulated in those simulators and the analysis will be done after.

The implementation will be done on the breadboard after analyzing that the results got from the simulator are the expected ones. The soldering will then follow.

### **1.5 SIGNIFICANCE**

Cell Phone usage was found to be one of the ways in which students may be distracted while at school. However, it is not only at school that cellphones are prohibited but also in places like hospitals and other confidential rooms. Many hobby projects were developed for cell phone detectors but were left unused. Putting these hobby projects to life will pay a great contribution to education today and bringing it at a cheap price will help in removing cell phone usage completely in places where it is prohibited.

## CHAPTER 2 LITERATURE REVIEW

This part will review some researches and experiences of cellphone usage which supports the background of the proposed research project. The NewTimes [10] wrote an article about mobile phone usage in schools and classrooms. It stated that, “while the world continues to celebrate this telecommunication innovation, it goes without saying that a section of society is lamenting mobile phone usage by those who shouldn’t be using them especially students” and that, “many educators who have had a chance to teach students with mobile phones in class have to admit that disruptions caused by incoming calls, ringtones, movement of students in and out of class when receiving calls and texting are not only disgusting but also inhibitive.” Additionally, the government of Rwanda has banned the use of mobile phones among students in primary and secondary school to fight distraction and protect them from the risks of human trafficking [11]. Research done by Louis-Philippe Beland and Richard Murphy showed that the effect of banning mobile phones from school premises adds up to the equivalent of an extra week’s schooling over a pupil’s academic year [12]. Furthermore, research work was performed by Jumoke, Oloruntoba, and Blessing to understand and also find the correlation between the academic performance of students and the usage of mobile phones during class hours. The information from this work was carried out using structured questionnaires administered to 45 students to get their individual views. In addition, 15 extensive interviews were done concurrently to have a grounded knowledge of the students with the data gathered during the course of this study. Findings indicated that students are influenced negatively to a great extent by the mobile phone because attention is focused on chatting, music, and others while their academic activities are neglected and left to suffer. Also, this study discovered that the use of the mobile phone is uncontrollable among students which is the leading cause of poor academic performance among students [13].

## CHAPTER 3 SYSTEM ANALYSIS AND DESIGN

In this project, two circuits were developed for 2G, 3G, and 4G networks.

There are many parameters that make 2G, 3G, and 4G networks differ from one another, and one of them is *the speed*:

- 1G : The analog 1G offered simple telephony service without data.
- 2G : Delivered digital signal and offered up to 250Kbps speed. Supports voice, text and data services.
- 3G : At least 200Kbps up to 3Mbps speed.
- 4G : 4G delivers up to 100Mbps for mobile access, and up to 1Gbps for wireless access. Most wireless carriers offering HSPA (High Speed Packet Access) at up to 6Mbps are claiming that they offer a 4G network [14].

Two stages were followed which are, "*Simulation and hardware implementation.*"

The following chart shows the processes followed from the beginning of the hardware implementation:

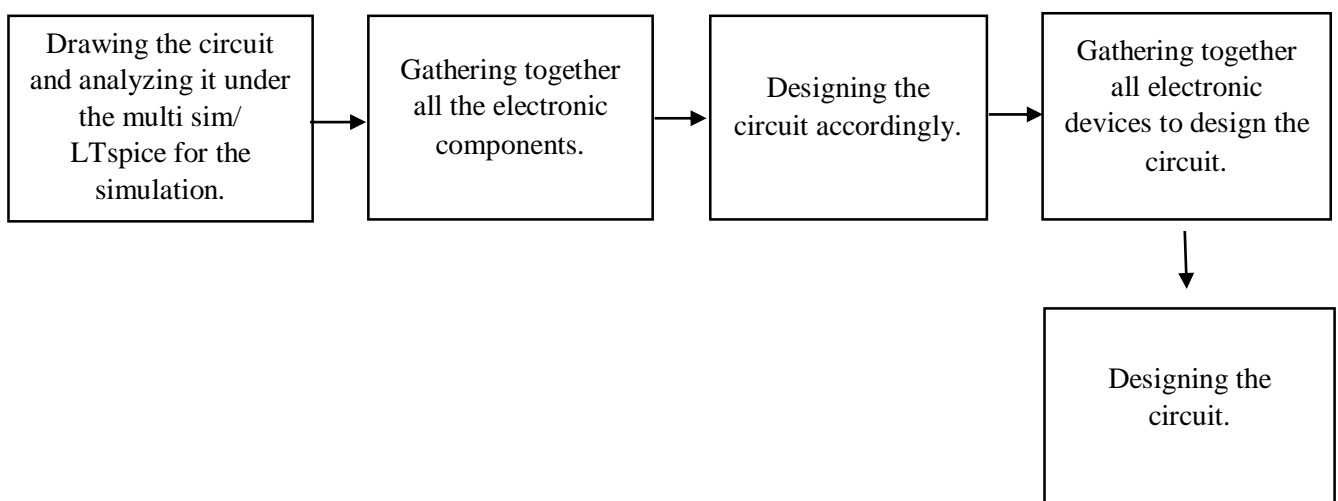

- a. The simulation: it was done by LTSpice and Multisim which are both electronics softwares. Simulation was first used because it helps in knowing the faulty designs before the implementation.

- *Multisim*: An electronic schematic capture and simulation program of National Instruments (NI). It can be used to process fast the analysis and design of various circuits, including ones containing digital devices, transistors, diodes, op amps, and even motors.

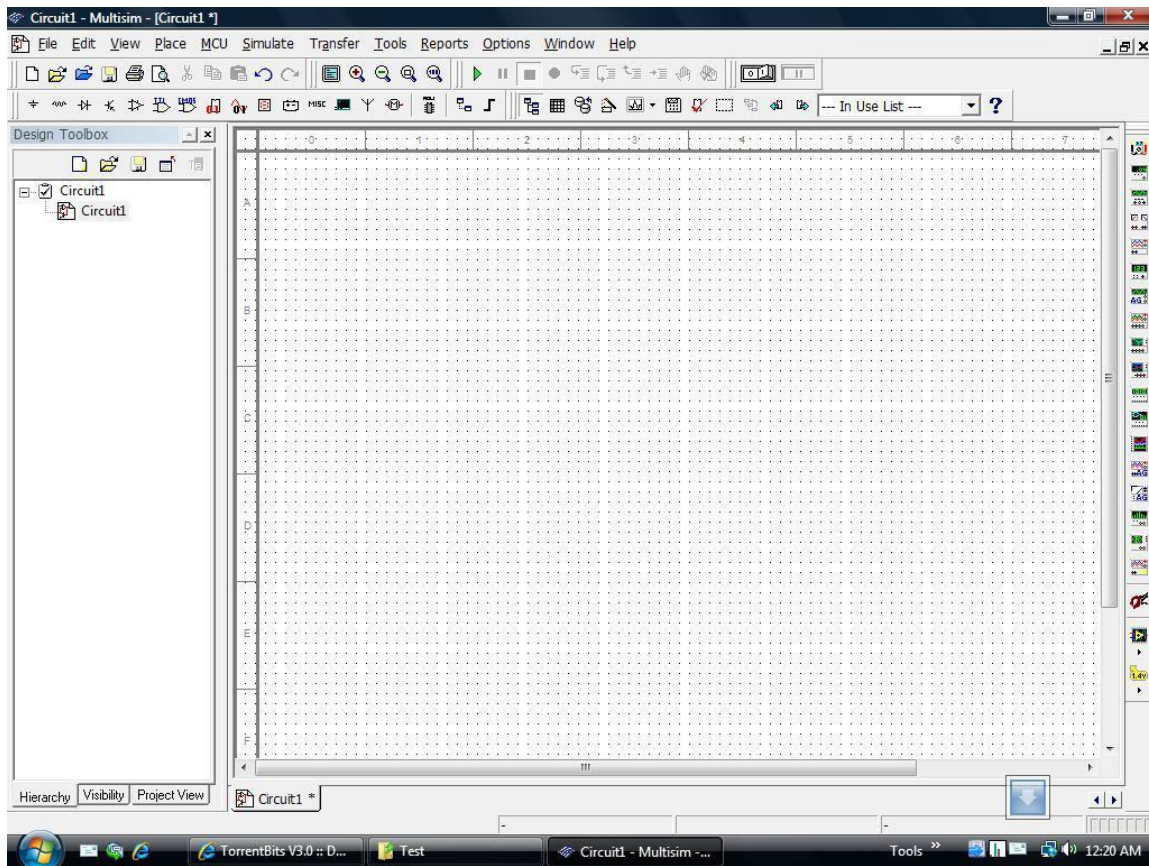

**Figure 1 - Multisim project window**

- *LTspice*: it is an analog devices' high performance circuit simulation program, which allows you to draft and analyze the performance of your circuit design. *a high performance SPICE simulator, schematic capture and waveform viewer with enhancements and models for easing the simulation of switching regulators.*

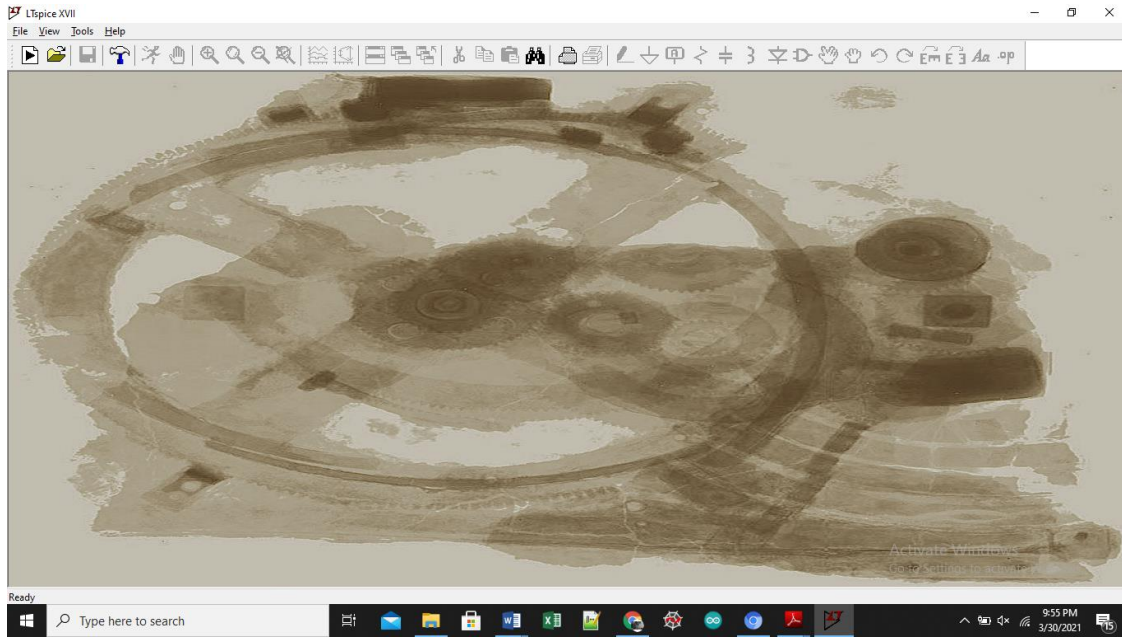

**Figure 2 - LTspice project window**

# CHAPTER 4 SYSTEM DEVELOPMENT, IMPLEMENTATION AND RESULTS

## 4.1 Development

The circuit for 2G and 3G networks is divided into 2 parts, “*The detection part and the sound generation part.*”

The whole circuit is made of the following components:

Resistors	Capacitors	- LED (2)
- $2.2M\Omega$ (2), $100K\Omega$	- $22pF$ (2), $0.22\mu F$ , $100\mu F$	- CA3130
- $1K\Omega$ (2), $12K\Omega$ , $15K\Omega$	- $47pF$ , $0.1\mu F$ (2),	- BC548
	- $0.01\mu F$ , $4.7\mu F$	- Buzzer
		- Antenna
		- 9V battery

### CA3130

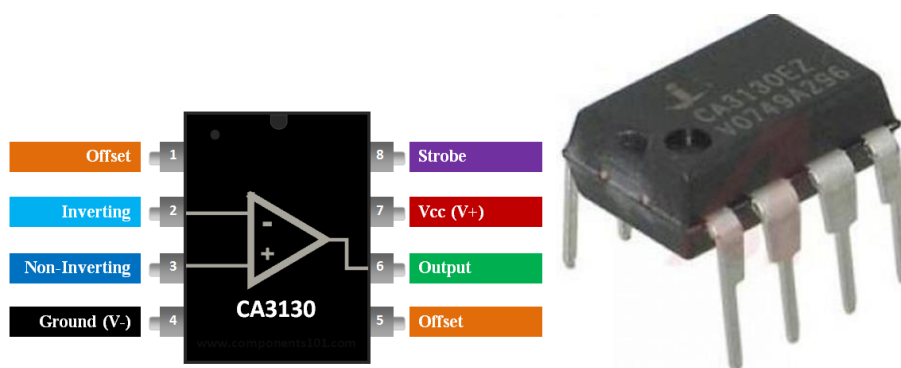

**A BiMOS Operational Amplifier with MOSFET.** It has the advantage of high bandwidth operation and less current consumption.

CA3130 specifications:

- Op-amp coupled with MOSFET at output
- Wide power supply Range  
Single supply  $-5V$  to  $16V$   
Dual supply:  $\pm 2.5V$  to  $\pm 8V$
- Input Terminal current:  $1mA$
- Maximum Output Voltage:  $13.3V$
- Maximum source current:  $22mA$
- Maximum sink current:  $20mA$
- Supply current:  $10mA$
- Common Mode Rejection Ration (CMRR):  $80dB$

NE555

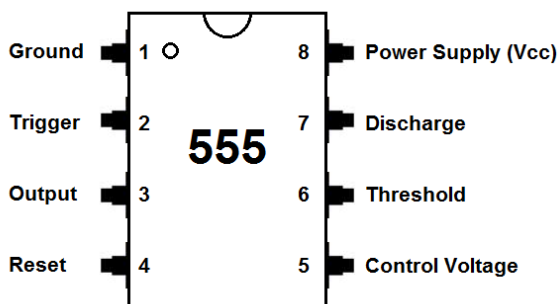

*NE555*: a very popular and useful precision timing device which can act as either a simple timer to generate single pulses or long time delays, or as a relaxation oscillator producing a string of stabilized waveforms of varying duty cycles from 50 to 100%.

BC548

This transistor is used in the circuit as a switch.

## 4.2 Implementation

2G and 3G circuit implementation:

The detection part of the circuit

The simulation of 2G and 3G circuit has been done first under the LTspice:

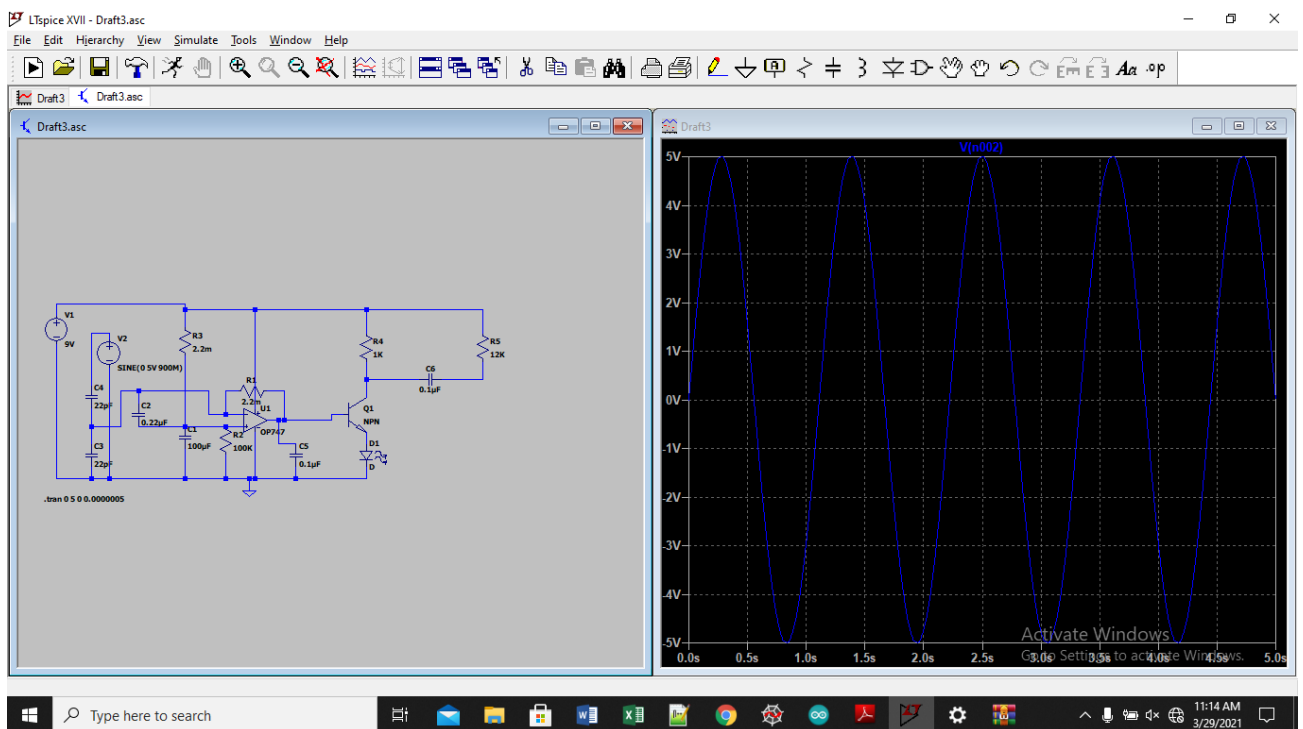
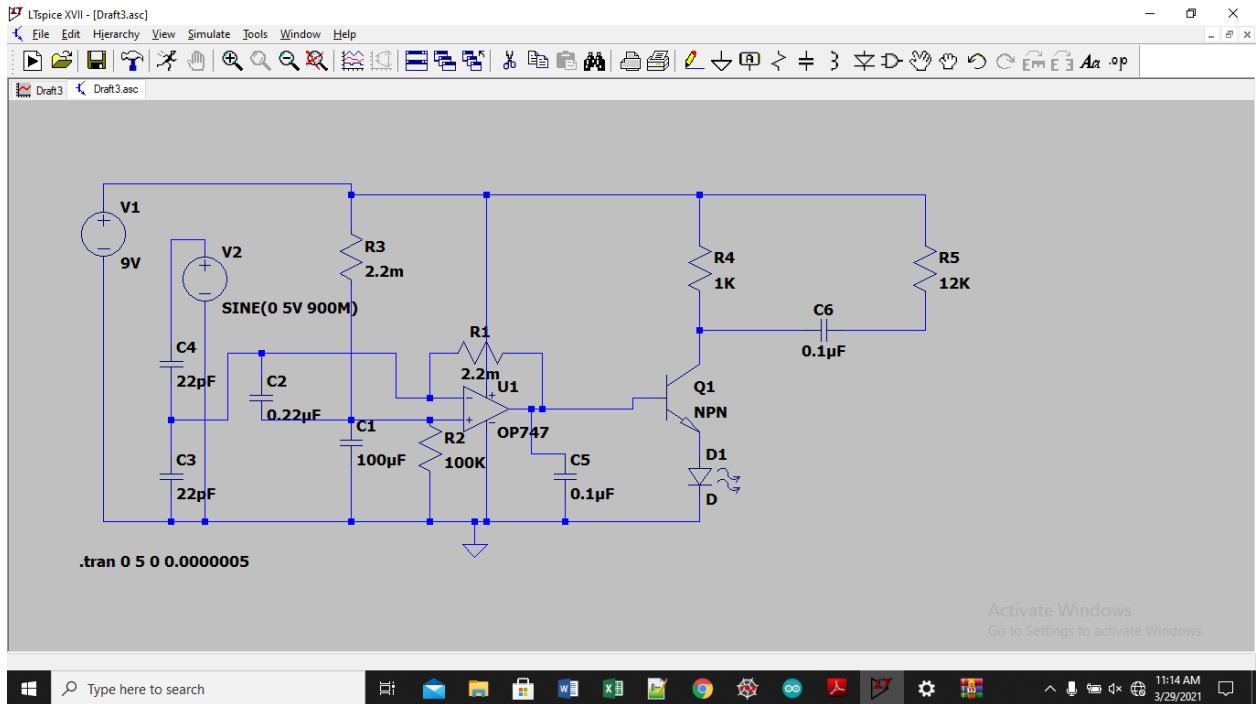

Figure 3 - the first part of the circuit (detection part)



**Figure 4 - the detection part of the 2G and 3G circuit.**

Explanation:

Figure 3 shows the detection part of the circuit that has been simulated, in the same window with the simulation part. This is the part which is made of op amp CA3130. The wave forms at the right shows the signal at the input in the circuit. Figure 4 shows the detection part of the circuit alone.

- During the simulation, OP747 has been used instead of CA3130. This is because it is not present in the version of LTspice XVII but OP747 possesses most of its characteristics.
- Capacitor C2 is used in order to detect the signal from the cellphone. It has the value of  $0.22\mu F$ . CA3130 is used in the circuit as *current to voltage convertor*. It is wired as an inverting amplifier with high gain. It amplifies the signal that is detected by capacitor C<sub>2</sub>. A capacitor of value  $47pF$  is connected across pin 1 and 8 and it's suitable for providing enough compensation for stable unity gain. In the above simulation, capacitor of value  $47pF$  is not added. But it is added during the implementation. Capacitors C<sub>3</sub> and C<sub>4</sub> which are both  $22pF$  are used in the circuit to filter the input signal.
- Capacitor C<sub>1</sub> of  $100\mu F$  is used to remove fluctuations in bias voltage (amount of voltage that an electronic device needs in order to power on and function).

- When the cell phone is active, it transmits the signal (in the range of 0.9 to 3GHz) in form of sine wave which passes through the space and it is the reason why the circuit is fed with sine wave properties. That signal disturbs the opamp and it's then sent to transistor BC548 (NPN) which is connected as a switch. Then the LED turns on.

### Detection part and sound generation

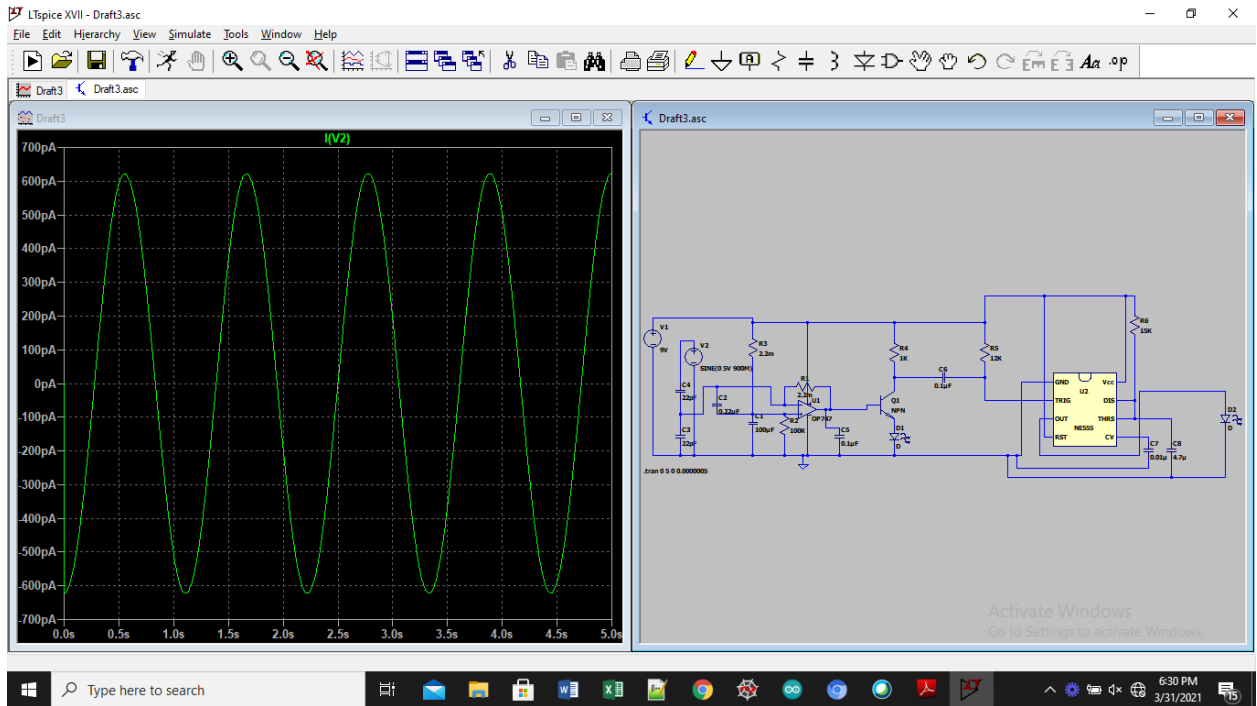

**Figure 5 - the whole circuit including the part of sound generation and the simulation**

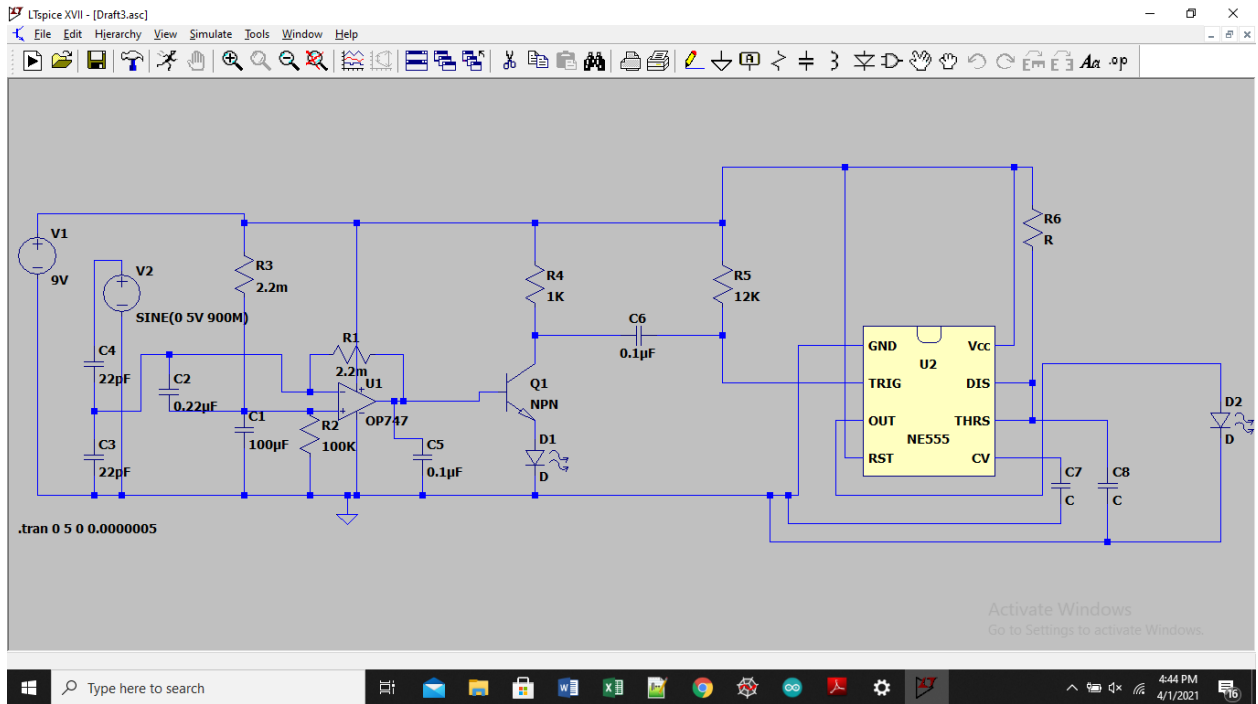

**Figure 6 - The detection part of the circuit and the sound generation part alone.**

The *figure 6* shows a circuit for 2G networks with all parts (detection part and sound generation part) included.

### Explanations

The first part (detection part) ends when the LED blinks which then triggers the pin 2 of the NE555 and the sound is generated, which is then heard in a buzzer. In the simulation the second LED represents the buzzer. NE555 is connected as monostable multivibrator where:

$$R_A = 15K\Omega \text{ and } C = 4.7\mu F$$

The pulse generated is given by the formula:  $t = 1.1RC$

$$\text{In the 2G circuit, } t = 1.1 \times 15000 \times 4.7 \times 10^{-6} = 77.55 \times 10^{-3} \text{seconds}$$

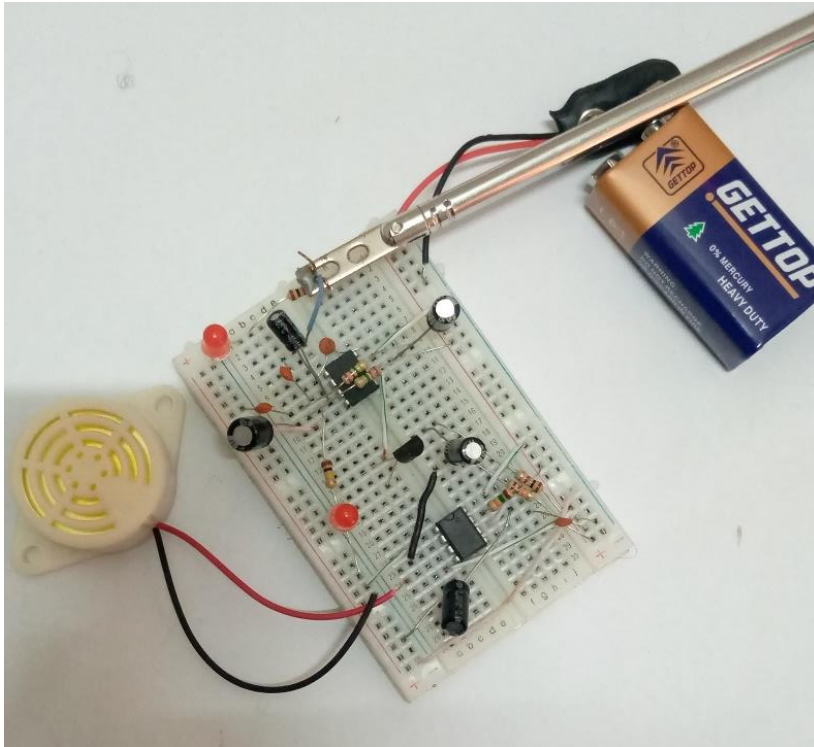

**Figure 7 - circuit implemented on the breadboard for 2G and 3G networks**

The soldered circuit for 2G

The 2G network has been simulated in the multisim and soldered on PCB.

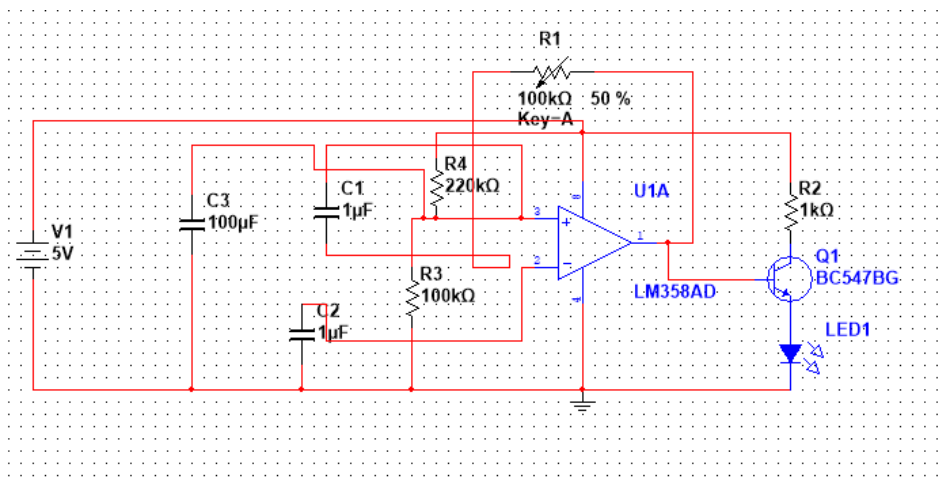

**Figure 8 - The simulated circuit for 2G networks in the multisim**

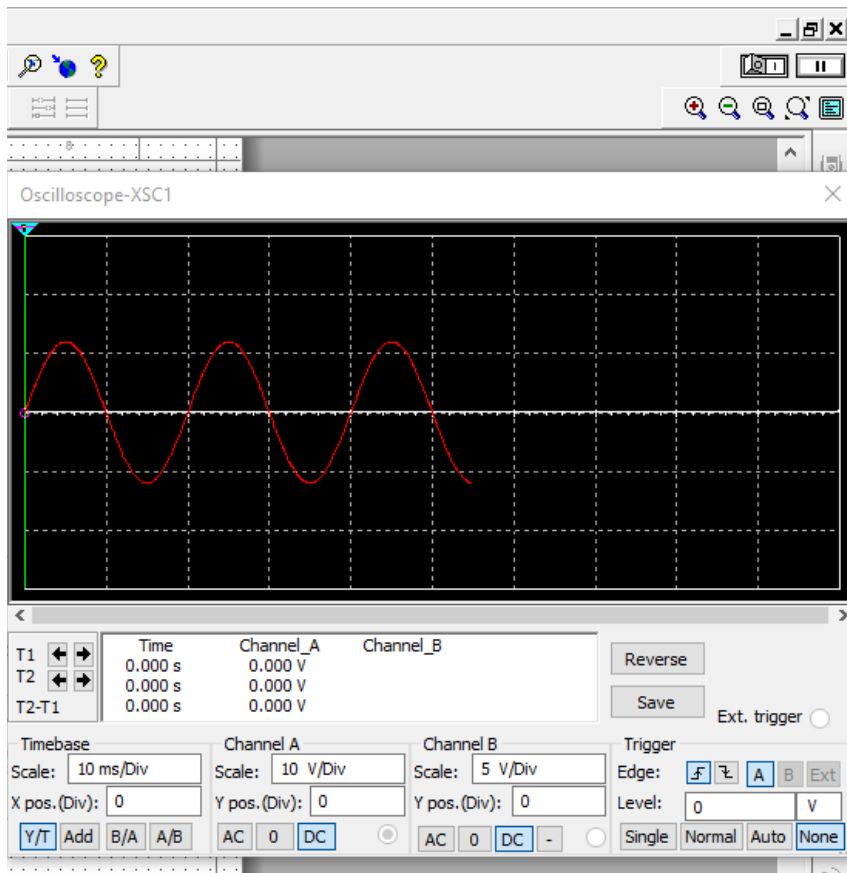

**Figure 9 - the 2G circuit simulated in the multisim for the input signal at low frequencies.**

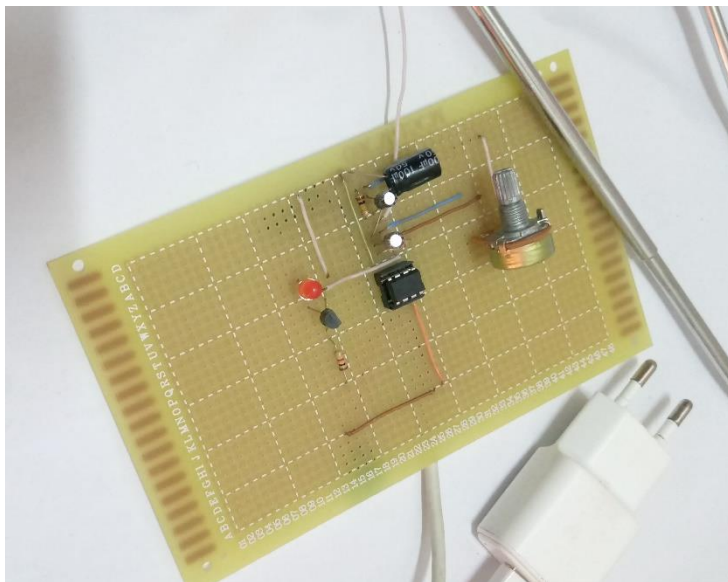

**Figure 10 - The 2G network circuit soldered on the PCB.**

### Explanations

Capacitor  $C_1$  is used in the circuit in order to detect the signal from cellphones. It then passes the signal to the input of the LM358 and the LED blinks. The transistor BC547 is used in the circuit as an amplifier to amplify the signal at the input of LM358. This circuit works on supply of 5V.

### 4.3 Results

The 2G circuit which has been implemented is able to detect cellphones in 1m. When a cellphone is nearby, and if a person is making/ receiving a call or sending/receiving a message, the buzzer produces a sound as LED continuously blinks. This happens as long the cellphone is receiving the signal.

This circuit in *figure 6* works perfectly for 2G networks and 3G circuits as well but the reaction is very slow (to 3G networks).

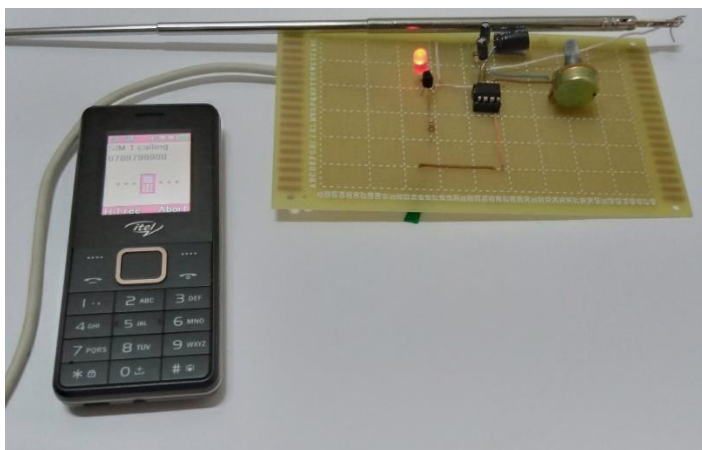

**Figure 11 - LED blinking while making a phone call.**

The pocket size design



Figure 12 - The circuit simulated inside the box



Figure 13 - Cell phone detector enclosed (device) with cell phone aside

The short video showing the working of the cell phone detector:

<https://drive.google.com/file/d/1Qlm1G0Y2Ygn1Ax4ANz0wUrMOP2E9okBu/view?usp=sharing>

## CHAPTER 5 CONCLUSION AND RECOMMENDATION

### 5.1 RECOMMENDATION

Even though the circuit can easily detect 2G and 3G networks when receiving/ making a call or sending/ receiving a call, it needs to be developed so as to give reaction on Bluetooth (Bluetooth devices communicate using low-power radio waves on a frequency band between 2.400 GHz and 2.483.5 GHz) as well. The detection range of the normal circuit needs also to be increased using digital components in the circuit instead of increasing the length of the antenna.

### 5.2 CONCLUSION

The circuit in *figure 6* and *8* works well for 2G networks and 3G networks with some delays. They can all sense the presence of a cellphone when calling/receiving a phone call or sending/receiving a message even when the cellphone is in silent mode. The circuit in *figure 6* works with 3G networks but responds after a certain delay. For the 3G networks, another circuit was made using two *LM358* which shows some features of being able to detect the 3G networks and can work for the 4G network as well.

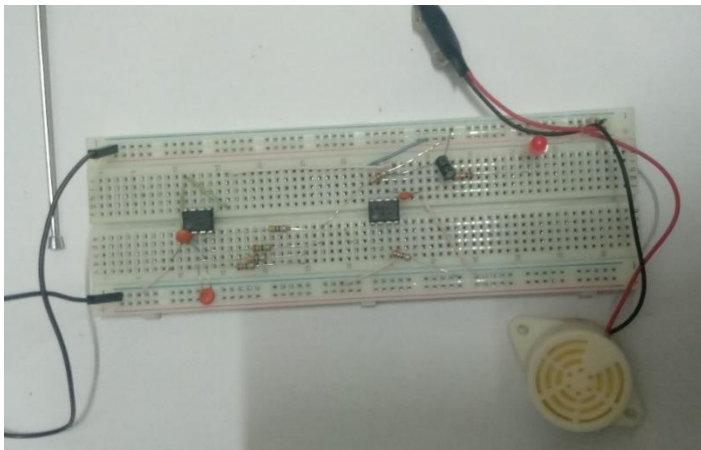

**Figure 14 - circuit being worked on for 3G networks.**

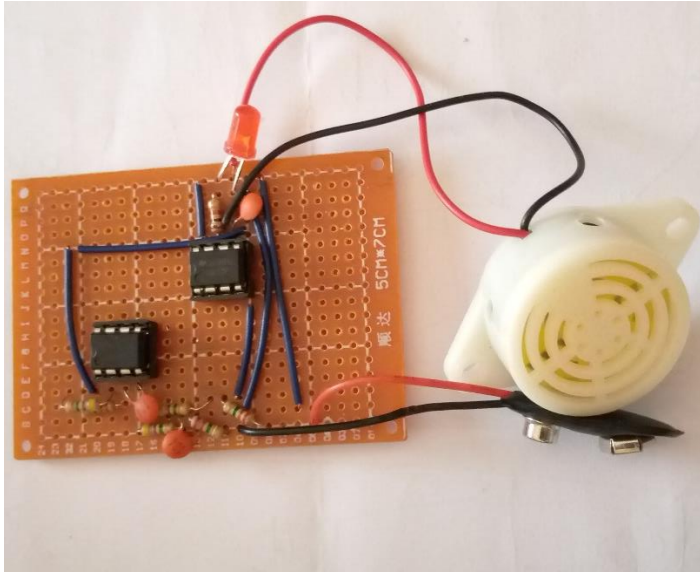

**Figure 15 - circuit for 3G, 4G networks after soldering on PCB**

## REFERENCES

- [1] Laura. S. (2019, February). Smartphone ownership is growing rapidly around the world, but not always equal. [online]. Available: <https://www.pewresearch.org/global/2019/02/05/smartphone-ownership-is-growing-rapidly-around-the-world-but-not-always-equally/>
- [2] Shanti. S. (2013). CELL PHONE IN THE HANDS OF STUDENTS-BOON OR TO BAN. [online]. Available: <https://www.semanticscholar.org/paper/CELL-PHONE-IN-THE-HANDS-OF-STUDENTS-BOON-OR-TO-BAN-Shanti-Phil./25a3117cbd9707f7f077019272bbd9e316f01b23>
- [3,5,6] Scott. W. (2006, July). Perceptions of mobile phones in college classrooms: Ringing, Cheating, and classroom policies [online]. Available: [https://www.researchgate.net/publication/233006151\\_Perceptions\\_of\\_Mobile\\_Phones\\_in\\_College\\_Classrooms\\_Ringing\\_Cheating\\_and\\_Classroom\\_Policies](https://www.researchgate.net/publication/233006151_Perceptions_of_Mobile_Phones_in_College_Classrooms_Ringing_Cheating_and_Classroom_Policies)
- [4] Ling. R. (2004, December). The mobile connection: the cellphone's impact on the society. [online]. Available: [https://www.researchgate.net/publication/331149811\\_The\\_mobile\\_connection\\_The\\_cell\\_phone's\\_impact\\_on\\_society](https://www.researchgate.net/publication/331149811_The_mobile_connection_The_cell_phone's_impact_on_society)

- [7] Nicholas.W.(2011, April). *STUDY OF CELLULAR PHONE DETECTION TECHNIQUES* [pdf].
- [8] Buhungiro.E.(2018, Aug). *Know your rights: Mobile phones are not allowed at school* [online]. Available: <https://www.newtimes.co.rw/lifestyle/know-your-rights-mobile-phones-are-not-allowed-school>
- [9] Mpirwa.E.(2018, June). *Government outlaws use of cell phones in schools*[online]. Available:<https://www.newtimes.co.rw/news/government-outlaws-use-cell-phones-schools>
- [10] Mayaka.Z. (2012, May). *Mobile phone usage in schools and classrooms*[online]. Available: <https://www.newtimes.co.rw/section/read/102531>
- [11] Oswald.N. (2018, June). *Rwanda bans use of mobile phones in school*[online]. Available: <https://www.ktpress.rw/2018/06/rwanda-bans-use-of-mobile-phones-in-schools/#:~:text=The%20government%20of%20Rwanda%20has,the%20risks%20of%20human%20trafficking.>
- [12] Jamie.D. (2015, May). *Schools that ban mobile phones see better academic results*[online]. Available:<https://www.theguardian.com/education/2015/may/16/schools-mobile-phones-academic-results>
- [13] Jumoke.S. (2015, January). *Analysis of Mobile Phone Impact on Student Academic Performance in Tertiary Institution*[online]. Available: [https://www.researchgate.net/publication/308412938\\_Analysis\\_of\\_Mobile\\_Phone\\_Impact\\_on\\_Student\\_Academic\\_Performance\\_in\\_Tertiary\\_Institution](https://www.researchgate.net/publication/308412938_Analysis_of_Mobile_Phone_Impact_on_Student_Academic_Performance_in_Tertiary_Institution)
- [14] Saravanan.S.(2017, July). *Difference between 2G, 3G, 4G and LTE*[online]. Available: <https://support.huawei.com/huaweiconnect/carrier/en/thread-360433.html#:~:text=In%20a%20nutshell%20the%20difference,4th%20generation%20of%20wireless%20technology.&text=3G%20%E2%80%93%20At%20least%20200Kbps%20up,to%201Gbps%20for%20wireless%20access.>